

*TB 9-6625-2124-35

DEPARTMENT OF THE ARMY TECHNICAL BULLETIN

CALIBRATION PROCEDURE FOR SWEEP OSCILLATOR, HEWLETT- PACKARD MODELS 8350A, 8350B, AND PLUG-IN HEWLETT-PACKARD MODELS 83525A, 83592A, AND 83592A OPT 002

Headquarters, Department of the Army, Washington, DC

9 July 2004

Distribution Statement A: Approved for public release; distribution is unlimited.

REPORTING OF ERRORS AND RECOMMENDING IMPROVEMENTS

You can improve this manual. If you find any mistakes or if you know of a way to improve these procedures, please let us know. Mail your letter or DA Form 2028 (Recommended Changes to Publications and Blank Forms) directly to: Commander, US Army Aviation and Missile Command, AMSAM-MMC-MA-NP, Redstone Arsenal, AL 35898-5000. A reply will be furnished to you. You may also provide DA Form 2028 information to AMCOM via e-mail, fax, or the World Wide Web. Our fax number is DSN 788-6546 or Commercial 256-842-6546. Our e-mail address is 2028@redstone.army.mil. Instructions for sending an electronic 2028 may be found at the back of this manual. For the World Wide Web, use <https://amcom2028.redstone.army.mil>.

SECTION		Paragraph	Page
I.	IDENTIFICATION AND DESCRIPTION		
	Test instrument identification	1	2
	Forms, records, and reports	2	2
	Calibration description	3	3
II.	EQUIPMENT REQUIREMENTS		
	Equipment required	4	5
	Accessories required	5	5
III.	CALIBRATION PROCESS FOR HEWLETT- PACKARD, MODELS 8350A AND 8350B		
	Preliminary instructions	6	6
	Equipment setup	7	6
	Tuning voltage.....	8	6
	Power supply	9	9
	Final procedure	10	10

*This bulletin supersedes TB 9-6625-2124-35, 3 May 1988.

	Paragraph	Page
IV. CALIBRATION PROCESS FOR PLUG-IN, HEWLETT-PACKARD, MODEL 83525A		
Preliminary instructions.....	11	10
Equipment setup	12	10
CW frequency accuracy and stability	13	11
Swept frequency and marker accuracy.....	14	13
Output power.....	15	17
AM ON/OFF ratio and square wave symmetry	16	20
Final procedure	17	21
V. CALIBRATION PROCESS FOR PLUG-IN, HEWLETT-PACKARD, MODELS 83592A and 83592A Opt 002		
Preliminary instructions.....	18	21
Equipment setup	19	22
CW frequency accuracy and stability	20	22
Swept frequency and marker accuracy.....	21	27
Output power.....	22	32
Step attenuation accuracy (Opt 002 only)	23	37
AM ON/OFF ratio and square wave symmetry	24	38
Final procedure	25	38

**SECTION I
IDENTIFICATION AND DESCRIPTION**

1. Test Instrument Identification. This bulletin provides instructions for the calibration of Sweep Oscillator, Hewlett-Packard Models 8350A, 8350B and Plug-in, Hewlett-Packard, Models 83525A, 83592A, and 83592A Opt 002. The manufacturers' manuals were used as the prime data sources in compiling these instructions. The equipment being calibrated will be referred to as the TI (test instrument) throughout this bulletin.

a. Model Variations. Variations among models are described in text.

b. Time and Technique. The time required for this calibration is approximately 6 hours, using the microwave technique.

2. Forms, Records, and Reports

a. Forms, records, and reports required for calibration personnel at all levels are prescribed by TB 750-25.

b. Adjustments to be reported are designated (R) at the end of the sentence in which they appear. When adjustments are in tables, the (R) follows the designated adjustment. Report only those adjustments made and designated with (R).

3. Calibration Description. TI parameters and performance specifications which pertain to this calibration are listed in table 1.

Table 1. Calibration Description

Test instrument parameters	Performance specifications
Models 8350A and 8350B	
Tuning voltage	Range: 0, 5, and 10 V dc Accuracy: ± 0.04%
Model 83525A	
CW frequency	Range: 0.01 to 8.4 GHz Accuracy: ± 5 MHz, 0.01 to 2 GHz ± 15 MHz, 2 to 8.4 GHz
Frequency stability	Accuracy: ±20 kHz at 10% line charge
Swept frequency	Range: 0.01 to 8.4 GHz Accuracy: ± 15 MHz, 0.01 to 2 GHz 2 ± 20 MHz, 2 to 8.4 GHz
Markers	Range: 0.01 to 8.4 GHz Accuracy: ± 15 MHz (± 0.5% sweep width) 0.01 to 2 GHz ± 20 MHz (± 0.5% sweep width) 2 to 8.4 GHz
Leveled output power	Range: -2 to +13 dBm Accuracy: ± 1.5 dBm
Power leveling	Range: 0.01 to 8.4 GHz Accuracy: ± 1.0 dB, internal leveling ± 0.1 dB, power meter leveling
AM ON/OFF ratio	Range: >30 dB at 1 and 4 GHz with +13 dBm output level
Square wave symmetry	Range: 40/60% (ON/OFF) at +13 dBm
Models 83592A and 83592A Opt 002	
CW frequency	Range: 0.01 to 20 GHz ¹ Accuracy: ± 5 MHz, 0.01 to 7 GHz ± 10 MHz, 7 to 13.5 GHz ± 15 MHz, 13.5 to 20 GHz ¹
Frequency stability	Accuracy: ± 50 kHz at 10% line change
Swept frequency	Range: 0.01 to 20 GHz ¹ Accuracy: ± 50 MHz, 0.01 to 20 GHz ¹ ± 15 MHz, 0.01 to 2.4 GHz ± 20 MHz, 2.4 to 7 GHz ± 25 MHz, 7 to 13.5 GHz ± 30 MHz, 13.5 to 20 GHz ¹

See footnote at end of table.

Table 1. Calibration Description Continued

Models 83592A and 83592A Opt 002								
Markers	Range:	0.01 to 20 GHz ¹						
	Accuracy:	± 15 MHz (± 0.5% sweep width) 0.01 to 2.4 GHz ± 20 MHz (± 0.5% sweep width) 2.4 to 7 GHz ± 25 MHz, (± 0.5% sweep width) 7 to 13.5 GHz ± 30 MHz (± 0.5% sweep width) 13.5 to 20 GHz ¹						
Leveled output power (83592A)	Range:	-5 to +10 dBm						
	Accuracy:	± 1.5 dB, 0.01 to 2.4 GHz ± 1.3 dB, 2.4 to 13.5 GHz ± 1.4 dB, 13.5 to 18.6 GHz ¹						
Leveled output power (83592A opt 002)	Range:	-5 to +10 dBm, 0.01 to 2.4 GHz -5 to 8.5 dBm, 2.4 to 7 GHz -5 to +8 dBm, 7 to 13.5 GHz -5 to +7 dBm, 13.5 to 18.6 GHz ¹						
	Accuracy:	± 1.7 dB, 0.01 to 2.4 GHz ± 1.5 dB, 2.4 to 13.5 GHz ± 1.6 dB, 13.5 to 18.6 GHz ¹						
Internal power leveling	Range:	0.01 to 20 GHz ¹						
	Accuracy:	± 0.9 dB, 0.01 to 2.4 GHz ± 0.7 dB, 2.4 to 13.5 GHz ± 0.8 dB, 13.5 to 20 GHz ¹						
Power meter leveling	Range:	0.01 to 20 GHz ¹						
	Accuracy:	± 0.2 dB						
Step attenuator (83592A Opt 002)	Range:	-10 to -70 dB						
	Accuracy:	Attenuator setting (dB)						
Frequency range 0.01 to 12.4 GHz tolerance in dB		10	20	30	40	50	60	70
		± 0.6	± 0.7	± 0.9	± 1.8	± 2.0	± 2.2	± 2.3
Frequency range 12.4 to 18 GHz tolerance in dB								
		± 0.7	± 0.9	± 1.2	± 2.0	± 2.3	± 2.5	± 2.8
Models 83592A and 83592A Opt 002								
AM ON/OFF ration	Range:	>30 dB at 1 and 4 GHz with +10 dBm output level						
Square wave symmetry	Range:	40/60% (ON/OFF) at +10 dBm						

¹Calibrated to 18 GHz only.

**SECTION II
EQUIPMENT REQUIREMENTS**

4. Equipment Required. Table 2 identifies the specific equipment to be used in this calibration procedure. This equipment is issued with Secondary Transfer Calibration Standards Sets AN/GSM-287, or AN/GSM-705. Alternate items may be used by the calibrating activity. The items selected must be verified to perform satisfactorily prior to use and must bear evidence of current calibration. The equipment must meet or exceed the minimum use specifications listed in table 2. The accuracies listed in table 2 provide a four-to-one ratio between the standard and TI. When the four-to-one ratio cannot be met, the actual accuracy of the equipment selected is shown in parenthesis.

5. Accessories Required. The accessories required for this calibration are common usage accessories issued as indicated in paragraph 4 above and are not listed in this calibration procedure. The following peculiar accessories are also required for this calibration: Directional Coupler, Narda, Model 3095 (3095); and Semiconductor Device (Crystal Detector), Hewlett-Packard, Model 423AOPT03 (7923182).

Table 2. Minimum Specifications of Equipment Required

Common name (official nomenclature)	Minimum use specifications	Manufacturer and model (part number)
ATTENUATOR (FIXED)	Range: 10 dB Accuracy: Determined in procedure	Weinschel, Model 9918-10dB (9918-10dB)
AUTOTRANSFORMER	Range: 108 to 125 V ac Accuracy: ±1%	General Radio, Type W10MT3AS3 (7910809) or Ridge, Model 9020A (9020A), or Ridge, Model 9020F (9020F)
FREQUENCY COUNTER	Range: 10.0 ms to 50 MHz Accuracy: ±0.05%	Fluke, Model PM6681/656 (PM6681/656)
MEASURING RECEIVER	Range: 0 to -70 dB Accuracy: ±7.5% Range: 0.850 to 18.0 GHz Accuracy: ±0.0625%	Hewlett-Packard, Model 8902A w/sensors, Hewlett-Packard, Model 11722A (11722A) and 11792A (11792A), and microwave converter, model 11793A (11793A)
MICROWAVE FREQUENCY COUNTER	Range: 5 MHz to 18 GHz Accuracy: ±5 X 10 ⁻⁶	Hewlett-Packard, Model 5352B- 001 (5352B-001)
MULTIMETER	Range: -40 to +20.0 V dc Accuracy: ±0.01%	Hewlett-Packard, Model 3458A (3458A)
OSCILLOSCOPE	Range: Dc to 10 ms	(OS-303/G)
POWER METER	Range: -6.5 to + 10 dBm Accuracy: ±6%	Hewlett-Packard, Model E12-432A (MIS-30525) w/thermistor mount, Hewlett-Packard, Model H75-478A (7915907) or 8478B (8478B)
SPECTRUM ANALYZER	Range: 1 to 4 GHz	(AN/USM-677)

SECTION III
CALIBRATION PROCESS FOR HEWLETT-PACKARD MODELS 8350A AND 8350B

6. Preliminary Instructions

a. The instructions outlined in paragraphs 6 and 7 are preparatory to the calibration process. Personnel should become familiar with the entire bulletin before beginning the calibration.

b. Items of equipment used in this procedure are referenced within the text by common name as listed in table 2.

c. Unless otherwise specified, verify the result of each test and, whenever the test requirement is not met, take corrective action before continuing with the calibration. Adjustments required to calibrate the TI are included in this procedure. Additional maintenance information is contained in the manufacturer's manual for this TI.

d. When indications specified in paragraph 8 are not within tolerance, perform the power supply check prior to making adjustments. After adjustments are made, repeat paragraph 8. Do not perform power supply check if all other parameters are within tolerance.

e. Unless otherwise specified, all controls and control settings refer to the TI.

7. Equipment Setup

WARNING

HIGH VOLTAGE is used or exposed during the performance of this calibration. DEATH ON CONTACT may result if personnel fail to observe safety precautions. REDUCE OUTPUT(S) to minimum after each step within the performance check where applicable.

NOTE

Plug-in must be removed during following performance checks.

a. Connect TI to a 115 V ac source.

b. Set LINE switch to ON and allow equipment to warm-up for 30 minutes.

8. Tuning Voltage

a. Performance Check

NOTE

If an out-of-tolerance condition is noted in (2) through (4) below, perform b below.

- (1) Connect multimeter to A4TP7 (-) and A4TP11 (+) (fig. 1).
- (2) Press **CW** key and enter data **0 MHz** on keyboard. Multimeter will indicate between -0.004 and +0.004 V dc.
- (3) Enter data **5 GHz** on keyboard. Multimeter will indicate between 4.996 and 5.004 V dc.
- (4) Enter data **10 GHz** on keyboard. Multimeter will indicate between 9.996 and 10.004 V dc.

b. Adjustments

(1) Connect multimeter to A4TP7 (-) and A4TP14 (+) (fig. 1). Adjust A4R59 (fig. 1) for multimeter indication of 10.0000 V dc (R).

(2) Disconnect multimeter from TI and connect frequency counter to **POS Z BLANK** (rear panel).

(3) Press function keys and enter corresponding data on keyboard as listed in (a) and (b) below:

(a) **INSTL PRESET** key.

(b) **SWEEP TIME** key, **DATA ENTRY** 10 ms.

(4) Adjust A5R2 (fig. 1) for frequency counter indication of 10.000 ms (R).

(5) Press function keys and enter corresponding data on keyboard as listed in (a) and (b) below:

(a) **INSTR PRESET** key.

(b) **SWEEP TIME** key, **DATA ENTRY** 1 s.

(6) Adjust A5R25 (fig. 1) for frequency counter indication of 1000 ms (R).

(7) Disconnect frequency counter from TI and connect multimeter to A4TP7 (-) and A4TP11 (+) (fig. 1).

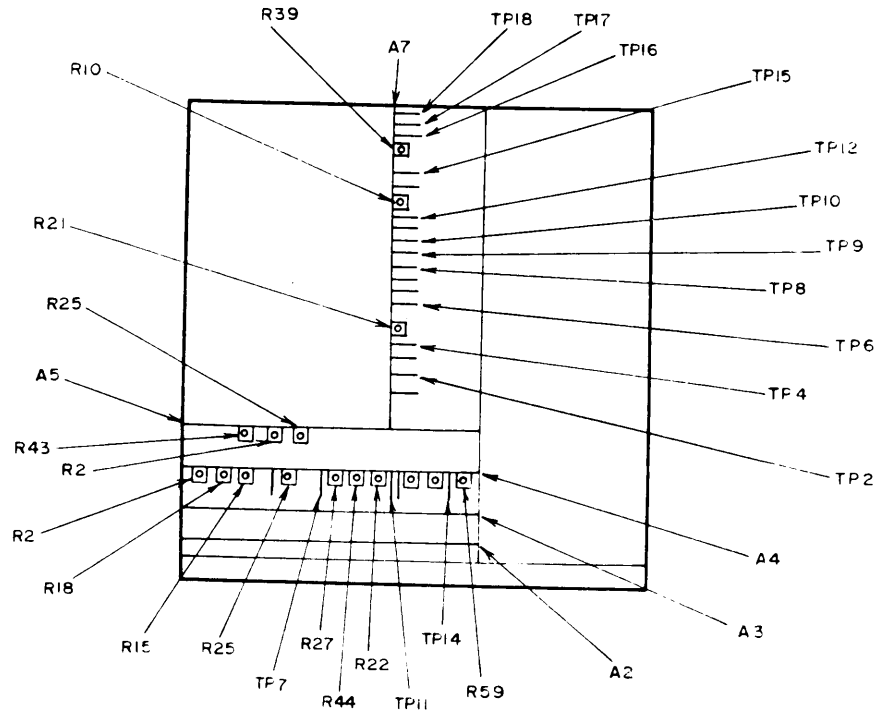

Figure 1. Test instrument mainframe - adjustment locations.

(8) Press function keys and enter corresponding data on keyboard as listed in (a) through (f) below:

- (a) **INSTR PRESET** key.
- (b) **SHIFT** key, **DATA ENTRY 00**.
- (c) **M1** key, **DATA ENTRY 2016**.
- (d) **M2** key, **DATA ENTRY GHz 9**.
- (e) **M1** key, **DATA ENTRY 2017**.
- (f) **M2** key, **DATA ENTRY BKSP dBm**.

(9) The **FREQUENCY/TIME**, display will indicate **FE**. Adjust A5R43 (fig. 1) for multimeter indication of 110 V dc (R).

(10) Press function key and enter corresponding data on keyboard as listed in (a) through (e) below:

- (a) **INSTR PRESET** key.
- (b) **CW** key, **DATA ENTRY -2000 MHz**.
- (c) **SHIFT** key **DATA. ENTRY 00**.
- (d) **M1** key, **DATA ENTRY 3000**.
- (e) **M2** key, **DATA ENTRY 01**.

(11) The **FREQUENCY/TIME** display will indicate 01. Adjust A4R44 (fig. 1) for multimeter indication of -0.20508 V dc (R).

(12) Enter data **BKSP** on keyboard. The **FREQUENCY/TIME** display will indicate **FF**. Adjust A4R22 (fig. 1) for multimeter indication of -0.19492 V dc (R).

(13) Enter data **80** on keyboard. The **FREQUENCY/TIME** display will indicate 80 and the multimeter will indicate -0.2000 V dc.

(14) Press function keys and enter corresponding data on keyboard as listed in (a) and (b) below:

- (a) **INSTR PRESET** key.
- (b) **CW** key, **DATA ENTRY 10.2 GHz**.

(15) Adjust A4R27 (fig. 1) for multimeter indication of 10.2000 V dc (R).

(16) Press function keys and enter corresponding data on keyboard as listed in (a) through (c) below:

- (a) **INSTR PRESET** key.
- (b) **ΔF** key, **DATA ENTRY 10.4 GHz**.
- (c) **SWEEP MAN** key, **DATA ENTRY 10.2 GHz**.

(17) Adjust A4R25 (fig. 1) for multimeter indication of 10.2000 V dc (R).

(18) Enter data -200 MHz on keyboard. Adjust A4R2 (fig. 1) for multimeter indication of -0.2000 V dc (R).

(19) Press **ΔF** key and enter data **0 GHz** on keyboard. If multimeter does not indicate 5.00000 V dc, press **VERNIER** key and adjust **FREQUENCY VERNIER** control for 5.00000 V dc multimeter indication.

(20) Press **ΔF** key and enter data **1.299 GHz**. Adjust A4R15 (fig. 1) for multimeter indication of 4.35064 V dc (R).

(21) Press **ΔF** key and enter data **162.4 MHz** on keyboard. Adjust A4R18 (fig. 1) for multimeter indication of 4.91883 V dc (R).

9. Power Supply

NOTE

Do not perform power supply checks if all other parameters are within tolerance.

NOTE

Install plug-in in TI prior to performing this check.

a. Performance Check

(1) Connect multimeter to A7TP16 (-) and A7TP15 (+) (fig. 1). If multimeter does not indicate between 19.990 and 20.010 V dc, perform **b** (1) below.

(2) Disconnect multimeter from A7TP16 and A7TP15. Connect to A7TP17 (-) and A7TP18 (+) (fig. 1). If multimeter does not indicate between -39.980 and -40.020 V dc, perform **b** (2) below.

TB 9-6625-2124-35

(3) Disconnect multimeter from A7TP17 and A7TP18. Connect to A7TP8 (-) and A7TP9 (+) (fig. 1). If multimeter does not indicate between -9.995 and -10.005 V dc, perform **b** (3) below.

b. Adjustments

- (1) Adjust A7R10 (fig. 1) for multimeter indication of 20.000 V dc (R).
- (2) Adjust A7R39 (fig. 1) for multimeter indication of -40.000 V dc (R).
- (3) Adjust (fig. 1) for multimeter indication of -10.000 V dc (R).

10. Final Procedure

- a. Deenergize and disconnect all equipment.
- b. Annotate and affix DA label/form in accordance with TB 750-25.

SECTION IV

CALIBRATION PROCESS FOR PLUG-IN, HEWLETT-PACKARD MODEL 83525A

11. Preliminary Instructions

a. The instructions outlined in paragraphs **11** and **12** are preparatory to the calibration process. Personnel should become familiar with the applicable sections before beginning the calibration.

b. Items of equipment used in this procedure are referenced within the text by common name as listed in table 2.

c. Unless otherwise specified, verify the result of each test and, whenever the test requirement is not met, take corrective action before continuing with the calibration. Adjustments required to calibrate the TI are included in this procedure. Additional maintenance information is contained in the manufacturer's manual for this TI.

d. Unless otherwise specified, all controls and control settings refer to the TI.

12. Equipment Setup

WARNING

HIGH VOLTAGE is used or exposed during the performance of this calibration. DEATH ON CONTACT may result if personnel fail to observe safety precautions. REDUCE OUTPUT(S) to minimum after each step within the performance check where applicable.

NOTE

TI must be inserted into a calibrated Hewlett-Packard, Model 8350 mainframe.

- a. Remove TI protective cover as required for adjustment.
- b. Connect mainframe to autotransformer.

- c. Connect autotransformer to a 115 V ac source and adjust for 115 V output.
- d. Set **LINE** switch to **ON** and allow at least 1 hour for equipment to warm-up and stabilize.

13. CW Frequency Accuracy and Stability

a. Performance Check

- (1) Connect equipment as shown in figure 2.

NOTE

Connect to microwave frequency counter input 1 or 2 as determined by frequency measurement requirement.

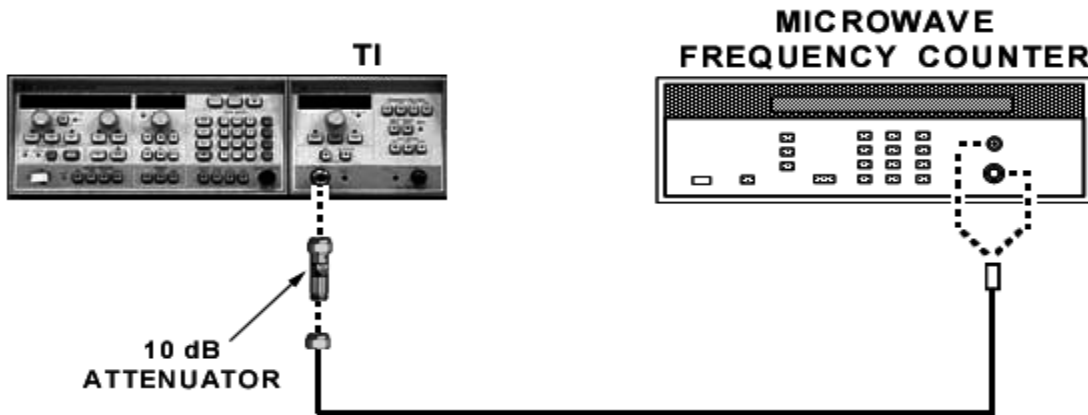

Figure 2. CW frequency accuracy – equipment setup

- (2) Press function keys and enter corresponding data on keyboard as listed in (a) through (c) below:

- (a) **INSTR PRESET** key.
- (b) **CW** key, **DATA ENTRY 50 MHz**.
- (c) **POWER LEVEL** key, **DATA ENTRY 10 dBm**.

- (3) Adjust **FREQ CAL** for microwave frequency counter indication of 50.00 MHz.

- (4) Enter data **10 MHz** on keyboard. Microwave frequency counter will indicate between 5.0 and 15.0 MHz; if not, perform **b** below.

- (5) Enter data on keyboard as listed in table 3. Microwave frequency counter will indicate as specified; if not, perform **b** below.

Table 3. CW Frequency Accuracy

Test instrument data entry	Frequency counter indications (GHz)	
	Min	Max
1 GHz	0.995	1.005
2 GHz	1.995	2.005
2.1 GHz	2.085	2.115
6.0 GHz	5.985	6.015
8.4 GHz	8.385	8.415

TB 9-6625-2124-35

- (6) Enter data **1 GHz** on keyboard. Record microwave frequency counter indication.
- (7) Adjust autotransformer for 108 V ac output. Microwave frequency counter will indicate within ± 20 kHz of value recorded in (6) above.
- (8) Adjust autotransformer for 125 V ac output. Microwave frequency counter will indicate within ± 20 kHz of value recorded in (6) above.
- (9) Adjust autotransformer for a 115 V ac output.

b. Adjustments

- (1) Press **INSTR PRESET** and **STOP** keys. Enter data **2 GHz** on keyboard.
- (2) Press TI (plug in) **AMPTD MKR** key (ON). Connect microwave frequency counter to A8TP1 (fig. 3).
- (3) Adjust A8C4 (fig. 3) for microwave frequency counter indication of 50,000,000 ± 250 Hz (R).

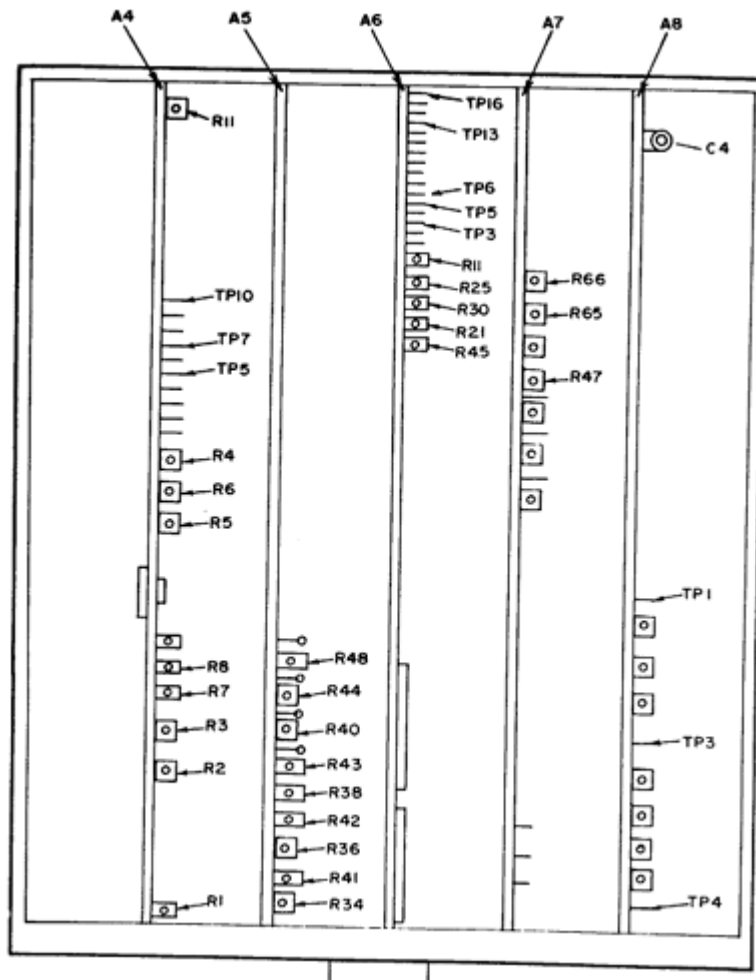

Figure 3. Model 83525A plug-in - adjustment locations.

14. Swept Frequency and Marker Accuracy

a. Performance Check

- (1) Connect equipment as shown in figure 4.
- (2) Press function keys and enter corresponding data on keyboard as listed in (a) through (d) below:
 - (a) **INSTR PRESET** key.
 - (b) **START** key, **DATA ENTRY 1 GHz**.
 - (c) **STOP** key, **DATA ENTRY 2 GHz**.
 - (d) **SWEEP TIME** key, **DATA ENTRY 105 ms**.

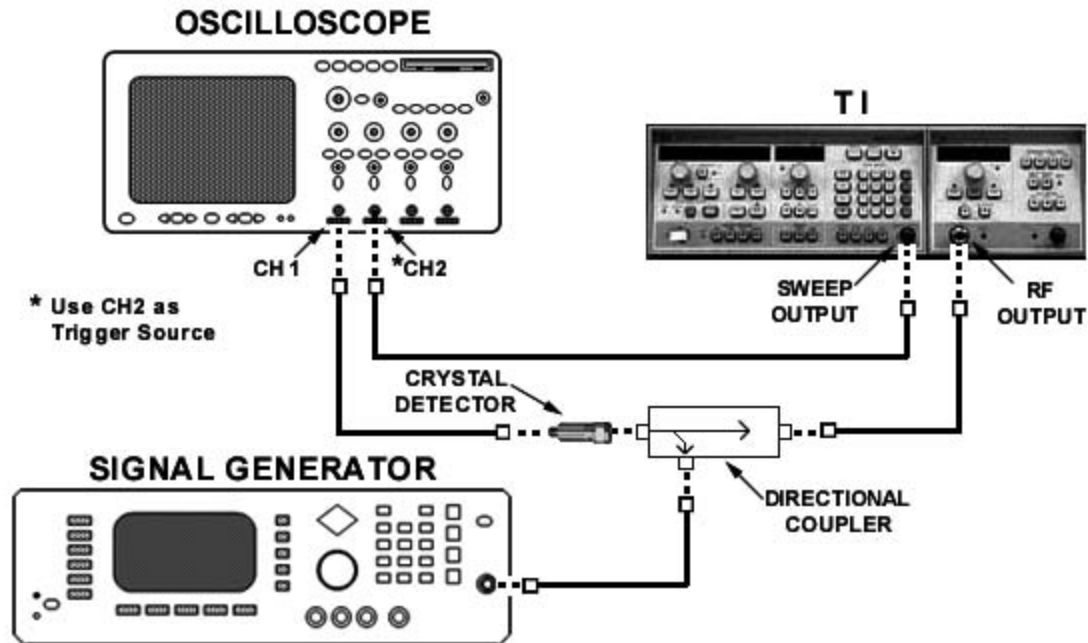

Figure 4. Swept frequency and marker accuracy - equipment setup.

- (3) Press **RF BLANK** key (ON) and adjust oscilloscope controls as necessary to display the TI sweep.
- (4) Adjust synthesized signal generator frequency and output level controls until a birdie (notch) appears on oscilloscope display (approximately 1 GHz).
- (5) Adjust synthesized signal generator frequency to align birdie with the start of TI sweep as indicated on oscilloscope display.
- (6) Synthesized signal generator frequency will indicate between 0.985 and 1.015 GHz.

NOTE

If an out-of-tolerance condition is noted in (6) above, or (7) through (23) below, perform **b** below.

(7) Adjust synthesized signal generator frequency to align the birdie with the end of TI sweep as indicated on oscilloscope display.

(8) Synthesized signal generator frequency will indicate between 1.985 and 2.015 GHz.

(9) Press function keys and enter corresponding data on keyboard as listed in (a) through (e) below:

- (a) **INSTR PRESET** key.
- (b) **START** key, **DATA ENTRY 10 MHz**.
- (c) **STOP** key, **DATA ENTRY 2 GHz**.
- (d) **M1** key, **DATA ENTRY 1 GHz**.
- (e) **M2** key, **DATA ENTRY 1.8 GHz**.

(10) Press **AMPTD MKR** (sweep oscillator) key (ON) and ensure plug-in **AMPTD MKR** is off.

(11) Repeat (3) above.

(12) Adjust oscilloscope position control to display **M1** (first) marker on crt, increasing oscilloscope horizontal timing setting as necessary.

(13) Adjust synthesized signal generator frequency to align the birdie with the leading of M1 marker on oscilloscope display. Synthesized signal generator frequency will indicate between 0.975 and 1.025 GHz.

(14) Repeat technique of (12) and (13) above for M2 marker. Synthesized signal generator frequency will indicate between 1.775 and 1.825 GHz.

(15) Press function keys and enter corresponding data on keyboard as listed in (a) through (d) below:

- (a) **START** key, **DATA ENTRY 2 GHz**.
- (b) **STOP** key, **DATA ENTRY 8.4 GHz**.
- (c) **M1** key, **DATA ENTRY 2.5 GHz**.
- (d) **M2** key, **DATA ENTRY 8 GHz**.

(16) Repeat (3) above.

(17) Repeat (12) above.

(18) Repeat technique of (13) above. Synthesized signal generator frequency will indicate between 2.448 and 2.552 GHz.

(19) Repeat technique of (12) and (13) above for M2 marker. Synthesized signal generator frequency will indicate between 7.948 and 8.052 GHz.

(20) Repeat (3) and (5) above.

(21) Synthesized signal generator frequency will indicate between 1.980 and 2.020 GHz.

(22) Repeat (7) above.

(23) Synthesized signal generator frequency will indicate between 8.380 and 8.420 GHz.

b. Adjustments

- (1) Connect multimeter to A6TP3 (+) and A6TP5 (-) (fig. 3). Adjust A6R21 (fig. 3) for multimeter indication of -10.000 ± 0.001 V dc (R).
- (2) Connect multimeter to A6TP13 (+) and A6TP16 (-) (fig. 3).
- (3) Press function keys and enter corresponding data on keyboard as listed in (a) through (g) below:
 - (a) **CW** key, **DATA ENTRY 8.4 GHz**.
 - (b) **SHIFT** key, **DATA ENTRY 002 GHz 80**.
 - (c) **M2** key, **DATA ENTRY 00**.
 - (d) **↑** key
 - (e) **M2** key, **DATA ENTRY 40**.
 - (f) **↑** key.
 - (g) **M2** key, **DATA ENTRY 00**.
- (4) Adjust A6R11 (fig. 3) for multimeter indication of -6.250 V dc. Record multimeter indication.
- (5) Press function keys and enter corresponding data on keyboard as listed in (a) through (c) below:
 - (a) **M2** key, **DATA ENTRY BKSP**.
 - (b) **↓** key.
 - (c) **M2** key, **DATA ENTRY 4 BKSP**.
- (6) Adjust A6R30 (fig. 3) for a difference of 12.9968 V dc between the value recorded in (4) above and multimeter indication (R).
- (7) Press M2 key and enter data **0 BKSP** on keyboard. Adjust A6R25 (fig. 3) for multimeter indication of -12.6218 V dc (R).
- (8) Press function keys and enter corresponding data on keyboard as listed in (a) through (c) below:
 - (a) **M2** key, **DATA ENTRY GHz 0**.
 - (b) **↑** key.
 - (c) **M2** key, **DATA ENTRY 00**.
- (9) Adjust A6R11 (fig. 3) for multimeter indication of -19.5000 V dc.
- (10) Press **INSTR PRESET** key and repeat (3) through (9) above until no adjustment is necessary.
- (11) Ensure TI **SWEEP OUTPUT** is connected to oscilloscope **CH2** input.
- (12) Connect oscilloscope **CH1** input to A6TP6 (fig. 3). Set oscilloscope for an X verses Y function operation.
- (13) Press function keys and enter corresponding data on keyboard as listed in (a) through (d) below:
 - (a) **CW** key.
 - (b) **CP** key, **DATA ENTRY 2.05 GHz**.
 - (c) **ΔF** key, **DATA ENTRY 125 MHz**.

TB 9-6625-2124-35

(d) **M1** key, **DATA ENTRY 2.05 GHz**.

(14) Adjust oscilloscope controls as necessary to view TI M1 marker and band switch point (break in trace).

(15) Adjust A6R45 (fig. 3) to align the band switch point with M1 marker as indicated on oscilloscope display (R).

(16) Connect multimeter to A6TP6 (fig. 3) and chassis ground.

(17) Press **INSTR PRESET** and **CW** keys. Record multimeter indication.

(18) Press **CF** and **ΔF** keys. Enter data **0 MHz** on keyboard and adjust A7R47 (fig. 3) for multimeter indication equal to value recorded in (17) above (R).

(19) Disconnect multimeter from TI.

(20) Press function keys and enter corresponding data on keyboard as listed in (a) through (o) below:

(a) **INSTR PRESET** key.

(b) **START** key, **2.001 GHz**.

(c) **STOP** key, **DATA ENTRY 8.4 GHz**.

(d) **SWEEP TIME** key, **DATA ENTRY 10 ms**.

(e) **M1** key, **DATA ENTRY 2.30 GHz**.

(f) **AMPTD MKR** (sweep oscillator **ON**) key.

(g) **RF BLANK (ON)**.

(h) **SAVE** key, **DATA ENTRY 2**.

(i) **SWEEP TIME** key, **DATA ENTRY 200 ms**.

(j) **SAVE** key, **DATA ENTRY 1**.

(k) **M2** key, **DATA ENTRY 6.5 GHz**.

(l) **SAVE** key, **DATA ENTRY 3**.

(m) **SWEEP TIME** key, **DATA ENTRY 10 ms**.

(n) **SAVE** key, **DATA ENTRY 4**.

(o) **RECALL** key, **DATA ENTRY 1**.

(21) Adjust oscilloscope controls as necessary to view TI M1 marker.

(22) Adjust synthesized signal generator frequency and level controls as necessary to align the birdie on the leading edge of M1 marker as indicated on oscilloscope display.

(23) Press **RECALL** key and enter data **2** on keyboard. Adjust A7R65 (fig. 3) to align leading edge of M1 marker with birdie on oscilloscope display (R).

(24) Press **SWEEP TIME** key and manually vary **SWEEP TIME** from 10 to 200 ms, while readjusting A7R65 for minimum shift of M1 marker (typical shift should be within ± 5 MHz).

(25) Press **RECALL** key and enter data **3** on keyboard.

(26) Repeat technique of (21) and (22) above for M2 marker.

(27) Press **RECALL** key and enter data **4** on keyboard. Adjust A7R66 (fig. 3) to align leading edge of M2 marker with birdie on oscilloscope display (R).

(28) Press **SWEEP TIME** key and manually vary **SWEEP TIME** from 10 to 200 ms, while readjusting A7R66 for minimum shift of M2 marker (typical shift should be within ± 5 MHz).

15. Output Power

a. Performance Check

NOTE

Prior to performing this paragraph, the exact value of 10 dB attenuator at 50 MHz and 2.2 GHz must be determined.

- (1) Connect power meter and 10 dB attenuator to **RF OUTPUT**.
- (2) Connect **EXT/MTR ALC INPUT** to **RECORDER** output (rear of power meter).
- (3) Press function keys and enter corresponding data on keyboard as listed in (a) through (c) below:
 - (a) **INSTR PRESET** key.
 - (b) **SWEEP TIME** key, **DATA ENTRY 100 s**.
 - (c) **POWER LEVEL** key, **DATA ENTRY 13 dBm**.
- (4) Press **SWEEP TRIGGER SINGLE** and **ALC MODE MTR** keys. Adjust **CAL** until power meter indication plus attenuator value equals +13 dBm. Record power meter indication.
- (5) Press **SWEEP TRIGGER SINGLE** key and observe power meter indication during period **SWEEP LIGHT** is on. Power meter will indicate within ± 0.1 dBm of value recorded in (4) above.

NOTE

Disregard power meter fluctuation when TI changes bands.

- (6) Press **ALC MODE INT** key and disconnect cable from **EXT/MTR ALC INPUT**.
- (7) Press function keys and enter corresponding data on keyboard as listed in (a) through (c) below:
 - (a) **INSTR PRESET** key.
 - (b) **CW** key, **DATA ENTRY 50 MHz**.
 - (c) **POWER LEVEL** key, **DATA ENTRY 13 dBm**.
- (8) Power meter indication plus attenuator value will be between +11.5 and +14.5 dBm. Record power meter indication.
- (9) Press **CW** key and vary **FREQUENCY VERNIER** control to tune TI output frequency from 50 MHz to 8.4 GHz, while observing power meter indication. Power meter will indicate within ± 1.0 dBm of value recorded in (8) above.
- (10) Press function keys and enter corresponding data on keyboard as listed in (a) and (b) below:
 - (a) **CW** key, **DATA ENTRY 50 MHz**.
 - (b) **POWER LEVEL** key, **DATA ENTRY 10 dBm**.
- (11) Power meter indication plus attenuator value will be between +8.5 and +11.5 dBm.
- (12) Make data entry of **5 dBm** on keyboard. Power meter indication plus attenuator value will be between +3.5 and +6.5 dBm.

TB 9-6625-2124-35

(13) Make data entry of **0 dBm** on keyboard. Power meter indication plus attenuator value will be between -1.5 and +1.5 dBm.

(14) Make data entry of **-2 dBm** on keyboard. Power meter indication plus attenuator value will be between -3.5 and -0.5 dBm.

(15) Press function keys and enter corresponding data on keyboard as listed in (a) and (b) below:

(a) **CW** key, **DATA ENTRY 8.4 GHz**.

(b) **POWER LEVEL** key, **DATA ENTRY 13 dBm**.

(16) Power meter indication plus attenuator value will be between +11.5 and +14.5 dBm.

(17) Make data entry of **10 dBm** on keyboard. Repeat (11) through (14) above.

b. Adjustments

(1) Disconnect power meter from **RF OUTPUT**.

(2) Press function keys and enter corresponding data on keyboard as listed in (a) through (t) below:

(a) **INSTR PRESET** key.

(b) **CW** key, **DATA ENTRY 50 MHz**.

(c) **POWER LEVEL** key, **DATA ENTRY 0 dBm**.

(d) **SAVE** key, **DATA ENTRY 1**.

(e) **POWER LEVEL** key, **DATA ENTRY -2 dBm**.

(f) **SAVE** key, **DATA ENTRY 2**.

(g) **POWER LEVEL** key, **DATA ENTRY 2 dBm**.

(h) **CW** key, **DATA ENTRY 2.2 GHz**.

(i) **SAVE** key, **DATA ENTRY 3**.

(j) **CW** key, **DATA ENTRY 50 MHz**.

(k) **POWER LEVEL** key, **DATA ENTRY 9 dBm**.

(l) **SAVE** key, **DATA ENTRY 4**.

(m) **CW** key, **DATA ENTRY 2.2 GHz**.

(n) **SAVE** key, **DATA ENTRY 5**.

(o) **CW** key, **DATA ENTRY 50 MHz**.

(p) **POWER LEVEL** key, **DATA ENTRY 13 dBm**.

(q) **SAVE** key, **DATA ENTRY 6**.

(r) **CW** key, **DATA ENTRY 2.2 GHz**.

(s) **SAVE** key, **DATA ENTRY 7**.

(t) **RECALL** key, **DATA ENTRY 1**.

(3) Connect power meter to **RF OUTPUT**. Adjust A4R6 (fig. 3) for power meter indication of 0.0 dBm (R).

(4) Press **RECALL** key and enter data **2** on keyboard. Record power meter indication.

(5) Press **RECALL** key and enter data **3** on keyboard.

(6) Power meter indication will be equal to but opposite polarity of value recorded in (4) above (in respect to 0 dBm); if not, readjust A4R6 and repeat (4) and (5) above.

- (7) Press **RECALL** key and enter data **4** on keyboard. Adjust A4R7 (fig. 3) for power meter indication of +9.0 dBm (R).
- (8) Press **RECALL** key and enter data **5** on keyboard. If power meter does not indicate +9.0 dBm readjust A4R7 for power meter indication of one-half the difference from +9.0 dBm (example: power meter indicates +8.8 dBm, readjust +8.9 dBm).
- (9) Disconnect power meter from TI and connect attenuator to **RF OUTPUT**. Connect power meter to attenuator.
- (10) Press **RECALL** key and enter data **6** on keyboard. Adjust A4R2 (fig. 3) for power meter (plus attenuator value) indication of +13.0 dBm (R).
- (11) Press **RECALL** key and enter data **7** on keyboard. If power meter (plus attenuator value) does not indicate +13.0 dBm readjust A4R2 for one-half the difference from +13.0 dBm.
- (12) Press **RECALL** key and enter data **1** on keyboard. Repeat (3) through (11) above until no further adjustment is required.
- (13) Press function keys and enter corresponding data on keyboard as listed in (a) and (b) below:
- (a) **CW** key, **DATA ENTRY 2.2 GHz**.
 - (b) **POWER LEVEL** key, **DATA ENTRY 0 dBm**.
- (14) Record power meter indication.
- (15) Adjust **FREQUENCY VERNIER** control to tune TI output frequency to the start of Band 2 (approximately 2.5 GHz).

NOTE

When performing (15) above a sharp drop in power meter indication will be observed at the end of band 1 (band breakpoint). Continue to manually tune TI output frequency until power meter indication returns.

- (16) Adjust A4R5 (fig. 3) for power meter indication equal to value recorded in (14) above (R).
- (17) Press **RECALL** key and enter data **5** on keyboard. Record power meter indication.
- (18) Repeat (15) above.
- (19) Adjust A4R8 (fig. 3) for power meter indication equal to value recorded in (17) above (R).
- (20) Press **RECALL** key and enter data **7** on keyboard. Record power meter indication.
- (21) Repeat (15) above.
- (22) Adjust A4R3 (fig. 3) for power meter indication equal to value recorded in (20) above (R).
- (23) Connect **SWEEP OUTPUT** to oscilloscope **CH2** input.
- (24) Connect semiconductor device to **RF OUTPUT** and connect oscilloscope **CH1** input to semiconductor device.

TB 9-6625-2124-35

(25) Press function keys and enter corresponding data on keyboard as listed in (a) through (e) below:

- (a) **INSTR PRESET** key.
- (b) **START** key, **DATA ENTRY 10 MHz**.
- (c) **STOP** key, **DATA ENTRY 8.4 GHz**.
- (d) **POWER LEVEL** key, **DATA ENTRY 10 dBm**.
- (e) **RF BLANK (ON)** key.

(26) Set oscilloscope for an X versus Y function operation and adjust controls as necessary to display the TI output.

(27) Adjust A5R48 (fig. 3) for best overall trace flatness as displayed on oscilloscope (R).

(28) Adjust BP (breakpoint) and SL (slope) adjustments, listed in table 4, for best overall trace flatness as displayed on oscilloscope.

Table 4 . BP and SL Adjustments

BP adjustment (fig. 3) (R)	SL adjustment (fig. 3) (R)
A5R34	A5R41
A5R36	A5R42
A5R38	A5R43
A5R40	A5R44

NOTE

The BP adjustment determines at what frequency the corresponding SL adjustment takes effect.

(29) Press **POWER LEVEL** key and enter data **-2 dBm** on keyboard.

(30) Adjust A4R11 (fig. 3) until ALC oscillations appear on oscilloscope trace as shown in figure 5.

(31) Observe TI output on oscilloscope display and readjust A4R11 to remove all ALC oscillations.

16. AM ON/OFF Ratio and Square Wave Symmetry

a. Performance Check

(1) Connect spectrum analyzer to **RF OUTPUT**, using 10 dB attenuator.

(2) Press function keys and enter corresponding data on keyboard as listed in (a) through (d) below:

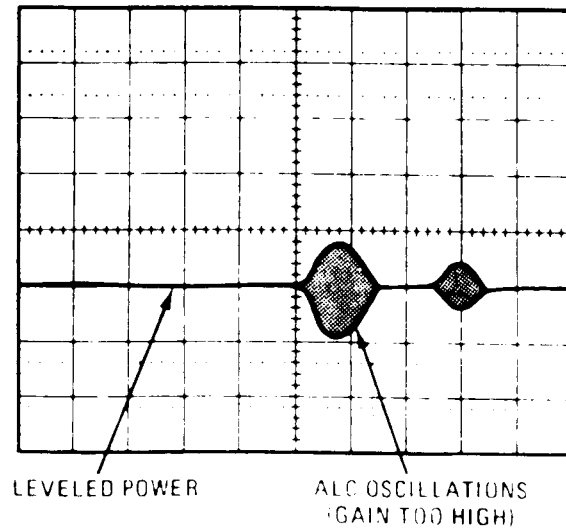

Figure 5. Leveled power trace showing ALC oscillations.

- (a) **INSTR PRESET** key.
- (b) **CW** key, **DATA ENTRY 1 GHz**.
- (c) **POWER LEVEL** key, **DATA ENTRY +13 dBm**.
- (d) \square **MOD(ON)**.

(3) Adjust spectrum analyzer controls as necessary to display the TI output signal.

(4) Measure **AM ON/OFF** ratio and square wave symmetry. **AM ON/OFF** ratio will be greater than 30 dB and square wave symmetry will be 40/60 percent.

(5) Press **CW** key and enter data **4 GHz** on keyboard. Repeat (3) and (4) above.

b. Adjustments. No adjustments can be made.

17. Final Procedure

- a.** Deenergize and disconnect all equipment.
- b.** Annotate and affix DA label/form in accordance with TB 750-25.

SECTION V CALIBRATION PROCESS FOR PLUG-IN, HEWLETT-PACKARD MODELS 83592A AND 83592A OPT 002

18. Preliminary Instructions

a. The instructions outlined in paragraphs 18 and 19 are preparatory to the calibration process. Personnel should become familiar with the applicable sections before beginning the calibration.

TB 9-6625-2124-35

b. Items of equipment used in this procedure are referenced within the text by common name as listed in table 2.

c. Unless otherwise specified, verify the result of each test and, whenever the test requirement is not met, take corrective action before continuing with the calibration. Adjustments required to calibrate the TI are included in this procedure. Additional maintenance information is contained in the manufacturer's manual for this TI.

d. Unless otherwise specified, all controls and control settings refer to the TI.

19. Equipment Setup

WARNING

HIGH VOLTAGE is used or exposed during the performance of this calibration. DEATH ON CONTACT may result if personnel fail to observe safety precautions. REDUCE OUTPUT(S) to minimum after each step within the performance check where applicable.

NOTE

TI must be inserted into a calibrated Hewlett-Packard, Model 8350 mainframe.

- a.** Remove TI protective cover as required for adjustment.
- b.** Connect mainframe to autotransformer (A2).
- c.** Connect autotransformer to a 115 V ac source and adjust for 115 V output.
- d.** Set **LINE** switch to **ON** and allow at least 1 hour for equipment to warm-up and stabilize.

NOTE

Due to many revisions of circuit boards in the TI, it may be necessary to refer to the manufacturer's manual to locate adjustments and test points on some TI's.

20. CW Frequency Accuracy and Stability

a. Performance Check

- (1) Connect equipment as shown in figure 2.

NOTE

Connect to microwave frequency counter input 1 or 2 as determined by frequency measurement requirement.

(2) Press function keys and enter corresponding data on keyboard as listed in (a) through (c) below:

- (a) **INSTR PRESET** key.
- (b) **CW** key, **DATA ENTRY 50 MHz**.
- (c) **POWER LEVEL** key, **DATA ENTRY 10 dBm**.

- (3) Adjust **FREQ CAL** for microwave frequency counter indication of 50.00 MHz.
- (4) Press **CW** key and enter data **10 MHz** on keyboard. Microwave frequency counter will indicate between 5.0 and 15.0 MHz; if not, perform **b** below.
- (5) Enter data on keyboard as listed in table 5. Microwave frequency counter will indicate as specified; if not, perform **b** below.
- (6) Enter data **1 GHz** on keyboard. Record microwave frequency counter indication.

Table 5. CW Frequency Accuracy

Test instrument data entry	Frequency counter indications (GHz)	
	Min	Max
1 GHz	0.995	1.005
2.4 GHz	2.395	2.405
4 GHz	3.995	4.005
2.5 GHz	2.495	2.505
7 GHz	6.995	7.005
10 GHz	9.990	10.010
7.1 GHz	7.090	7.110
13.5 GHz	13.490	13.510
17 GHz	16.985	17.015
14 GHz	13.985	14.015

- (7) Adjust autotransformer for 108 V ac output. Microwave frequency counter will indicate within ± 50 kHz of indication recorded in (6) above.
- (8) Adjust autotransformer for 125 V ac output. Microwave frequency counter will indicate within ± 50 kHz of indication recorded in (6) above.
- (9) Adjust autotransformer for 115 V ac output.

b. Adjustments

- (1) Connect multimeter to A8TP12 (+) and A8TP1 (-) (fig. 6).
- (2) Adjust A8R44 (fig. 6) for multimeter indication of -10.000 V dc (R).
- (3) Disconnect multimeter from A8TP12 and A8TP1. Connect to A6TP9 (+) and A6TP10 (-) (fig. 7).
- (4) Press **INSTR PRESET** and **CW** keys. Enter data **20 GHz** on keyboard.
- (5) Adjust **FREQUENCY VERNIER** control for multimeter indication of 10.000 V dc.
- (6) Disconnect multimeter from A6TP9 and A6TP10. Connect to A8TP6 (+) (fig. 6) and A7TP8 (-) (fig. 8).
- (7) Press function keys and enter corresponding data on keyboard as listed in (a) through (f) below:

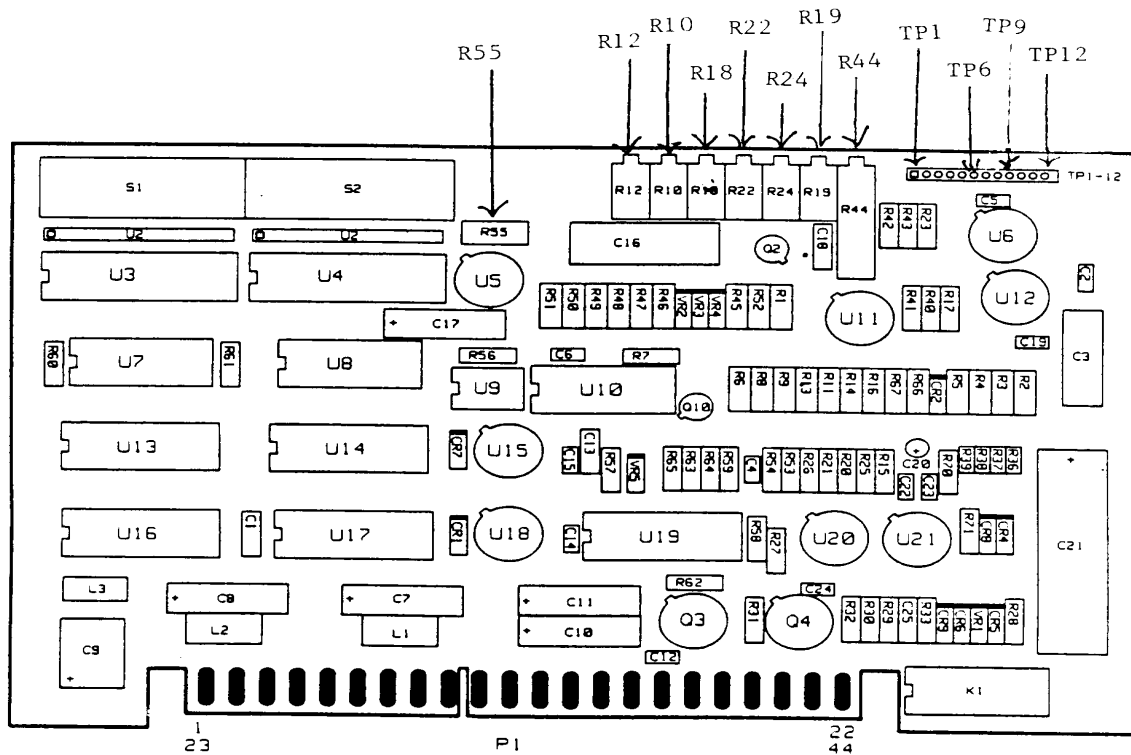

Figure 6. A8 board adjustment locations.

- (a) **SHIFT** key, **DATA ENTRY 002**.
 - (b) **GHz** key, **DATA ENTRY 80**.
 - (c) **M2** key, **DATA ENTRY 00**.
 - (d) **↑** key, **DATA ENTRY 00**.
 - (e) **↑** key, **DATA ENTRY 00**.
 - (f) **↑** key, **DATA ENTRY 00**.
- (8) The **FREQUENCY** display will indicate 2C83 and the **FREQUENCY/TIME** display will indicate 00; if not, repeat (3) through (7) above.
- (9) Adjust A8R22 (fig. 6) for multimeter indication of -7.000 V dc (R).
- (10) Press **↓** key two times. The **FREQUENCY** display will indicate **2C81**.
- (11) Press function keys and enter corresponding data on keyboard as listed in (a) through (d) below:
- (a) **↓** key, **DATA ENTRY 0 BKSP**.
 - (b) **↑** key, **DATA ENTRY 0 BKSP**.
 - (c) **↑** key, **DATA ENTRY 0 BKSP**.
 - (d) **↑** key, **DATA ENTRY 0 BKSP**.

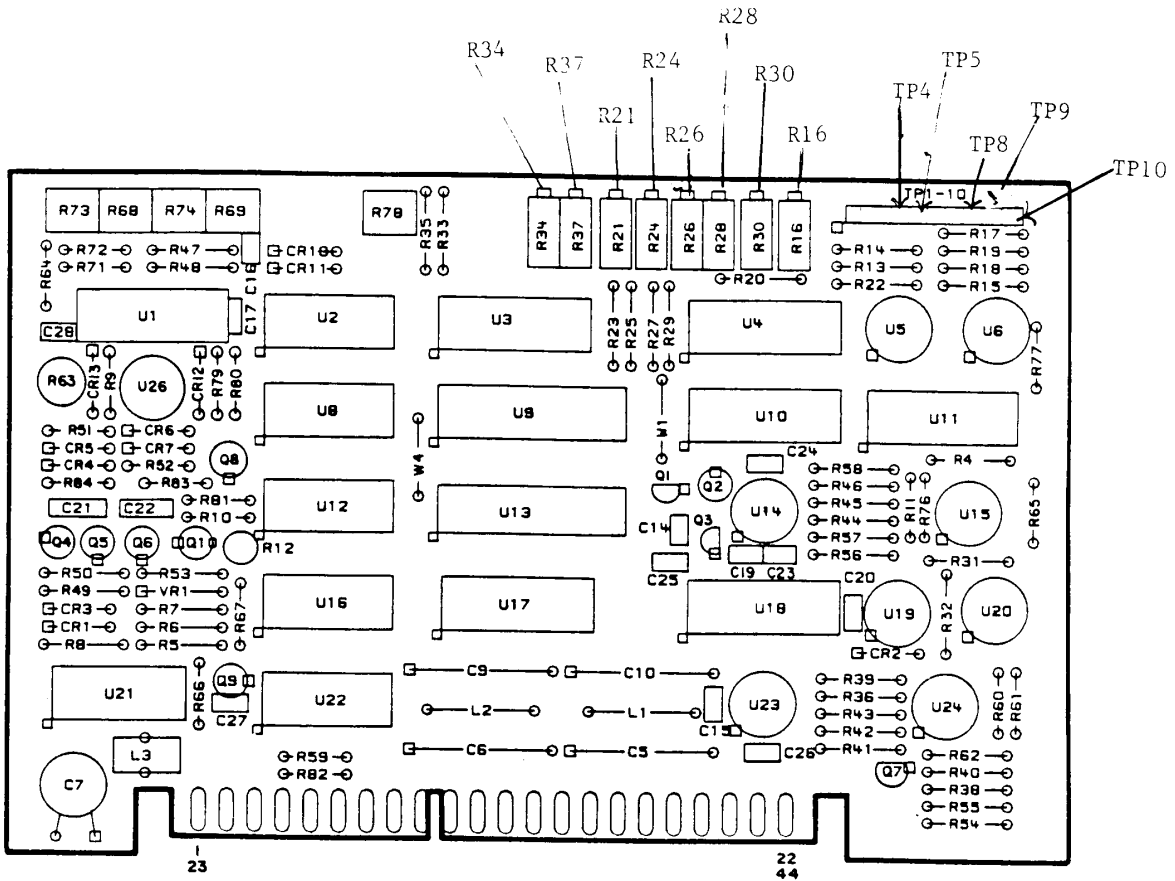

Figure 7. A6 board adjustment locations.

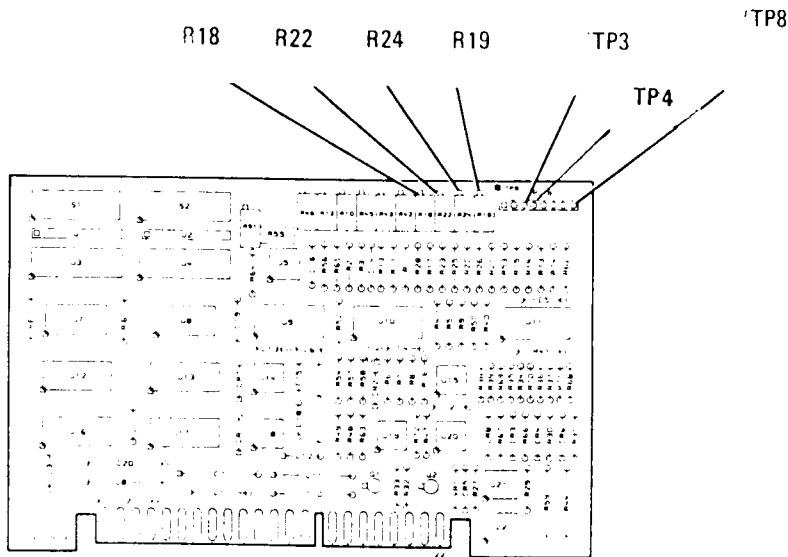

Figure 8. A7 board adjustment locations.

TB 9-6625-2124-35

(12) The **FREQUENCY** display will indicate **2C83** and the **FREQUENCY/TIME** display will indicate **0F**.

(13) Adjust A8R24 (fig. 6) for multimeter indication of -20.000 V dc (R).

(14) Repeat (10) above.

(15) Press function keys and enter corresponding data on keyboard as listed in (a) through (d) below:

- (a) ↓ key, **DATA ENTRY 0 BKSP**.
- (b) ↑ key, **DATA ENTRY 0 BKSP**.
- (c) ↑ key, **DATA ENTRY 0 BKSP**.
- (d) ↑ key, **DATA ENTRY 0 BKSP**.

(16) The **FREQUENCY** display will indicate **2C83** and the **FREQUENCY/TIME** display will indicate **F0**.

(17) Adjust A8R19 (fig. 6) for multimeter indication of -26.500 V dc (R).

(18) Press ↑ key four times. The **FREQUENCY** display will indicate **2C87**.

(19) Press function keys and enter corresponding data on keyboard as listed in (a) through (d) below:

- (a) ↑ key, **DATA ENTRY 00**.
- (b) ↑ key, **DATA ENTRY 00**.
- (c) ↑ key, **DATA ENTRY 00**.
- (d) ↑ key, **DATA ENTRY 00**.

(20) The **FREQUENCY** display will indicate **2C8B** and the **FREQUENCY/TIME** display will indicate **00**.

(21) Disconnect multimeter from A8TP6 and connect to A7TP3 (fig. 8). Adjust A7R22 (fig. 8) for multimeter indication of -3.000 V dc (R).

(22) Press ↓ key two times. The **FREQUENCY** display will indicate **2C89**.

(23) Press function keys and enter corresponding data on keyboard as listed in (a) through (d) below:

- (a) ↓ key, **DATA ENTRY 0 BKSP**.
- (b) ↑ key, **DATA ENTRY 0 BKSP**.
- (c) ↑ key, **DATA ENTRY 0 BKSP**.
- (d) ↑ key, **DATA ENTRY 0 BKSP**.

(24) The **FREQUENCY** display will indicate **2C8B** and the **FREQUENCY/TIME** display will indicate **0F**.

(25) Adjust A7R24 (fig. 8) for multimeter indication of -19.500 V dc (R).

(26) Repeat (22) above.

(27) Press function keys and enter corresponding data on keyboard as listed in (a) through (d) below:

- (a) ↓ key, **DATA ENTRY BKSP 0**.
- (b) ↑ key, **DATA ENTRY BKSP 0**.
- (c) ↑key, **DATA ENTRY BKSP 0**.

(d) ↑ key, **DATA ENTRY BKSP 0**.

(28) The **FREQUENCY** display will indicate **2C8B** and the **FREQUENCY/TIME** display will indicate **F0**.

(29) Adjust A7R19 (fig. 8) for multimeter indication of -9.500 V dc (R).

(30) Press keys as listed in (a) through (c) below:

(a) **INSTR PRESET**.

(b) **SHIFT**.

(c) **CW**.

(31) Disconnect multimeter from A7TP3 and A7TP8 and connect to A7TP4 (+) (fig. 8) and A8TP1 (-). Adjust A7R18 (fig. 8) for multimeter indication of 0.000 V dc (R).

(32) Disconnect multimeter from A7TP4 and connect to A8TP9 (fig. 6). Adjust A8R18 (fig. 6) for multimeter indication of 0.000 V dc (R).

21. Swept Frequency and Marker Accuracy

a. Performance Check

(1) Connect equipment as shown in figure 4.

(2) Press function keys and enter corresponding data on keyboard as listed in (a) through (j) below:

(a) **INSTR PRESET** key.

(b) **START** key, **DATA ENTRY 10 MHz**.

(c) **STOP** key, **DATA ENTRY 17.5 GHz**.

(d) **M1** key, **DATA ENTRY 1 GHz**.

(e) **M2** key, **DATA ENTRY 4 GHz**.

(f) **M3** key, **DATA ENTRY 8 GHz**.

(g) **M4** key, **DATA ENTRY 14 GHz**.

(h) **M5** key, **DATA ENTRY 17 GHz**.

(i) **SWEEP TIME** key, **DATA ENTRY 25 ms**.

(j) **POWER LEVEL** key, **DATA ENTRY 0 dBm**.

(3) Press **AMPTD MKR** and **RF BLANK** keys to **ON**.

(4) Adjust oscilloscope controls as necessary to display the TI sweep output. Five markers will be present on display.

NOTE

A break in oscilloscope trace will be present at each TI band switch point (2.4, 7.1, and 13.5 GHz).

(5) Adjust synthesized signal generator output level and frequency controls until a birdie (notch) appears on oscilloscope display.

(6) Adjust oscilloscope position control to display **M1** (first) marker on crt, increasing oscilloscope horizontal timing setting as necessary.

TB 9-6625-2124-35

(7) Adjust synthesized signal generator frequency control to align the birdie with the leading edge of M1 marker on oscilloscope display. Synthesized signal generator will indicate between 0.850 and 1.150 GHz.

NOTE

If an out-of-tolerance condition is noted in (7) above or (8) through (40) below, perform **b** below.

(8) Repeat technique of (6) and (7) above for TI markers listed in table 6. Synthesized signal generator will indicate as specified.

Table 6. Marker Accuracy

Test instrument marker	Microwave measurement system indication (GHz)	
	Min	Max
M2	3.850	4.150
M3	7.850	8.150
M4	13.850	14.150
M5	16.850	17.150

(9) Adjust synthesized signal generator frequency control to align the birdie with the end of TI sweep as indicated on oscilloscope display.

(10) Synthesized signal generator will indicate between 17.450 and 17.550 GHz.

(11) Press function keys and enter corresponding data on keyboard as listed in (a) through (d) below:

- (a) **START** key, **DATA ENTRY 10 MHz.**
- (b) **STOP** key, **DATA ENTRY 2.4 GHz.**
- (c) **M1** key, **DATA ENTRY 1 GHz.**
- (d) **M2** key, **DATA ENTRY 2 GHz.**

(12) Repeat (6) above.

(13) Repeat technique of (7) above. Synthesized signal generator will indicate between 0.974 and 1.026 GHz.

(14) Repeat technique of (6) and (7) above for M2 marker. Synthesized signal generator will indicate between 1.974 and 2.026 GHz.

(15) Repeat (9) above.

(16) Synthesized signal generator will indicate between 2.385 and 2.415 GHz.

(17) Press function keys and enter corresponding data on keyboard as listed in (a) through (j) below:

- (a) **START** key, **DATA ENTRY 2.4 GHz.**
- (b) **STOP** key, **DATA ENTRY 7 GHz.**
- (c) **M1** key, **DATA ENTRY 3 GHz.**
- (d) **M2** key, **DATA ENTRY 6 GHz.**
- (e) **M3** key.
- (f) **OFF** key.

- (g) **M4** key.
- (h) **OFF** key.
- (i) **M5** key.
- (j) **OFF** key.

(18) Repeat (6) above.

(19) Repeat technique of (7) above. Synthesized signal generator will indicate between 2.957 and 3.043 GHz.

(20) Repeat technique of (6) and (7) above for M2 marker. Synthesized signal generator will indicate between 5.957 and 6.043 GHz.

(21) Adjust synthesized signal generator to align the birdie with the start of TI sweep as indicated on oscilloscope display.

(22) Synthesized signal generator will indicate between 2.380 and 2.420 GHz.

(23) Repeat (9) above.

(24) Synthesized signal generator will indicate between 6.980 and 7.020 GHz.

(25) Press function keys and enter corresponding data on keyboard as listed in (a) through (d) below:

- (a) **START** key, **DATA ENTRY 7 GHz.**
- (b) **STOP** key, **DATA ENTRY 13.5 GHz.**
- (c) **M1** key, **DATA ENTRY 8 GHz.**
- (d) **M2** key, **DATA ENTRY 12 GHz.**

(26) Repeat (6) above.

(27) Repeat technique of (7) above. Synthesized signal generator will indicate between 7.9425 and 8.0575 GHz.

(28) Repeat technique of (6) and (7) above for M2 marker. Synthesized signal generator will indicate between 11.9425 and 12.0575 GHz.

(29) Repeat (21) above.

(30) Synthesized signal generator will indicate between 6.975 and 7.025 GHz.

(31) Repeat (9) above.

(32) Synthesized signal generator will indicate between 13.475 and 13.525 GHz.

(33) Press function keys and enter corresponding data on keyboard as listed in (a) through (d) below:

- (a) **START** key, **DATA ENTRY 13.5 GHz.**
- (b) **STOP** key, **DATA ENTRY 17.5 GHz.**
- (c) **M1** key, **DATA ENTRY 15 GHz.**
- (d) **M2** key, **DATA ENTRY 17 GHz.**

(34) Repeat (6) above.

(35) Repeat technique of (7) above. Synthesized signal generator will indicate between 14.9375 and 15.0625 GHz.

TB 9-6625-2124-35

(36) Repeat technique of (6) and (7) above for M2 marker. Synthesized signal generator will indicate between 16.9375 and 17.0625 GHz.

(37) Repeat (21) above.

(38) Synthesized signal generator will indicate between 13.470 and 13.530 GHz.

(39) Repeat (9) above.

(40) Synthesized signal generator will indicate between 17.470 and 17.530 GHz.

b. Adjustments

(1) Connect multimeter to A6TP9 (+) and A6TP10 (-) (fig. 7).

(2) Set switch **A3S1** (fig. 9) position 1 to the **OPEN** (UP) position.

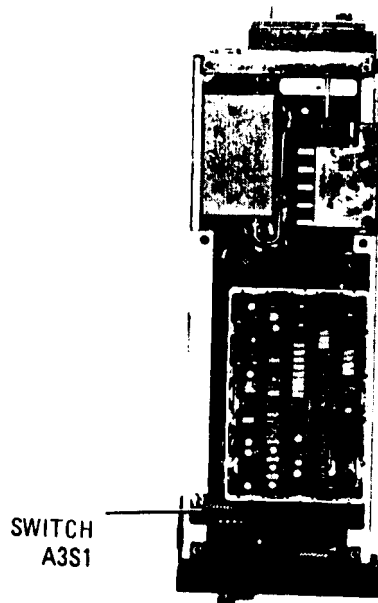

Figure 9. Switch A3S1 location.

(3) Press **INSTR PRESET** and **CW** keys. Enter data **20 GHz** on keyboard.

(4) Adjust **FREQUENCY VERNIER** control for multimeter indication of 10.000 V dc.

(5) Disconnect multimeter from A6TP9 and connect to A6TP5 (fig. 7). Adjust A6R16 (fig. 7) for multimeter indication -10.000 V dc (R).

(6) Disconnect multimeter from A6TP5 and connect to A6TP4 (fig. 7). Adjust A6R21 (fig. 7) for multimeter indication of 0.000 V dc (R).

(7) Disconnect multimeter from A6TP4 and connect to A6TP8 (fig. 7). Adjust A6R34 (fig. 7) for multimeter indication of -10.000 V dc (R).

(8) Press **CW** key and enter data **13.5 GHz** on keyboard.

(9) Connect multimeter to A6TP5 (+) and A6TP10 (-) (fig. 7).

(10) Adjust **FREQUENCY VERNIER** control for multimeter indication of -6.74837 V dc.

- (11) Disconnect multimeter from A6TP5 and connect to A6TP8. Adjust A6R24 (fig. 7) for multimeter indication of 0.000 V dc (R).
- (12) Press **CW** key and enter data **7 GHz** on keyboard.
- (13) Disconnect multimeter from A6TP8 and connect to A6TP5.
- (14) Adjust **FREQUENCY VERNIER** control for multimeter indication of -3.49675 V dc.
- (15) Disconnect multimeter from A6TP5 and connect to A6TP8.
- (16) Adjust A6R26 (fig. 7) for multimeter indication of 0.000 V dc.
- (17) Press **CW** key and enter data **2.4 GHz** on keyboard.
- (18) Repeat (13) above.
- (19) Adjust **FREQUENCY VERNIER** control for multimeter indication of -1.19560 V dc.
- (20) Repeat (15) above.
- (21) Adjust A6R28 (fig. 7) for multimeter indication of 0.000 V dc (R).
- (22) Press **CW** key and enter data **10 MHz** on keyboard.
- (23) Repeat (13) above.
- (24) Adjust **FREQUENCY VERNIER** control for multimeter indication of 0.00000 V dc.
- (25) Repeat (15) above.
- (26) Adjust A6R30 (fig. 7) for multimeter indication of 0.000 V dc (R).
- (27) Disconnect multimeter from TI. Connect **SWEEP OUTPUT** to oscilloscope **CH2** input.
- (28) Connect oscilloscope CH1 input to A6TP8. Press **INSTR PRESET** key.
- (29) Set oscilloscope as listed in (a) through (d) below:
 - (a) **CH1 VOLTS/DIV** to **.5**.
 - (b) **CH2 VOLTS/DIV** to **.5**.
 - (c) **CH1 input** to **DC**.
 - (d) **CH2 input** to **DC**.
- (30) Set oscilloscope for an X versus Y function operation and adjust oscilloscope controls as required to obtain a display as shown in figure 10.

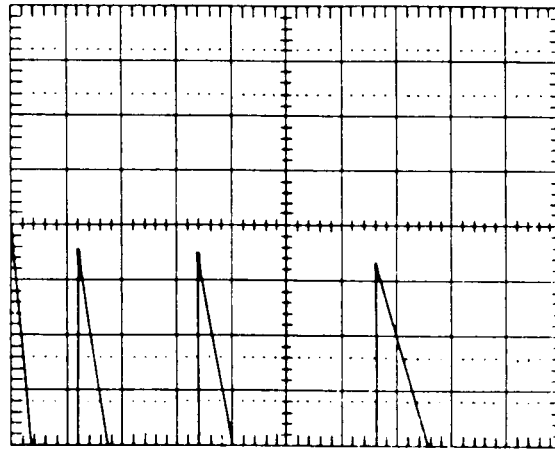

Figure 10. Oscilloscope display.

(31) Adjust oscilloscope CH1 **POSITION** control to align top of first ramp with display horizontal center graticule line.

(32) Adjust A6R37 (fig. 7) to align the tops of the second, third, and fourth ramps with the oscilloscope horizontal center graticule line (R).

(33) Return switch **A3S1** position 1 to the **CLOSED** (down) position.

22. Output Power

a. Performance Check

(1) Press function keys and enter corresponding data on keyboard as listed in (a) through (c) below:

- (a) **INSTR PRESET** key.
- (b) **CW** key, **DATA ENTRY 50 MHz**.
- (c) **POWER LEVEL** key, **DATA ENTRY 0.0 dBm**.

NOTE

Values in parenthesis pertain to Option 002.

(2) Connect power meter to **RF OUTPUT**. Power meter will indicate 0.0 ± 1.5 (1.7) dBm; if not, perform **b** (1) through (20) below.

(3) Manually adjust power control for power meter indication of +10.0 dBm. **POWER** display will indicate between 8.5 and 11.5 (8.3 and 11.7) dBm; if not, perform **b** (1) through (20) below.

(4) Manually adjust power control for power display indications listed in table 7. Power meter will indicate as specified; if not, perform **b** (1) through (20) below.

(5) Enter data **0 dBm** on keyboard. Record power meter indication.

(6) Press **CW** key and vary **FREQUENCY VERNIER** control to tune TI output frequency from 50 MHz to 2.4 GHz while observing power meter indication. Power meter will indicate within ± 0.9 dBm of value recorded in (5) above; if not, perform **b** (1) through (20) below.

(7) Enter data **2.5 GHz** on keyboard. Power meter will indicate 0.0 ± 1.3 (1.5) dBm. Record power meter indication.

Table 7. Output Power

Test instrument power display indications (dBm)	Power meter indications (dBm)	
	Min	Max
8.0	6.5 (6.3)	9.5 (9.7)
7.0	5.5 (5.3)	8.5 (8.7)
6.0	4.5 (4.3)	7.5 (7.7)
5.0	3.5 (3.3)	6.5 (6.7)
4.0	2.5 (2.3)	5.5 (5.7)
3.0	1.5 (1.3)	4.5 (4.7)
2.0	0.5 (0.3)	3.5 (3.7)
1.0	-0.5 (-0.7)	2.5 (2.7)
-1.0	-2.5 (-2.7)	0.5 (0.7)
-2.0	-3.5 (-3.7)	-0.5 (-0.3)
-3.0	-4.5 (-4.7)	-1.5 (-1.3)
-4.0	-5.5 (-5.7)	-2.5 (-2.3)
-5.0	-6.5 (-6.7)	-3.5 (-3.3)

(8) Vary **FREQUENCY VERNIER** control to tune TI output frequency from 2.5 to 7.0 GHz while observing power meter indication. Power meter will indicate within ± 0.7 dBm of value recorded in (7) above; if not, perform **b** (21) through (27) below.

(9) Enter data **7.1 GHz** on keyboard. Power meter will indicate 0.0 ± 1.3 (1.5) dBm. Record power meter indication.

(10) Vary **FREQUENCY VERNIER** control to tune TI output frequency from 7.1 to 13.5 GHz. Power meter will indicate within ± 0.7 dBm of value recorded in (9) above; if not, perform **b** (21) through (27) below.

(11) Enter data **13.6 GHz** on keyboard. Power meter will indicate 0.0 ± 1.4 (1.6) dBm. Record power meter indication.

(12) Vary **FREQUENCY VERNIER** control to tune TI output frequency from 13.6 to 18.0 GHz. Power meter will indicate within ± 0.8 dBm of value recorded in (11) above; if not, perform **b** (21) through (27) below.

(13) Disconnect power meter from **RF OUTPUT**.

(14) Press function keys and enter corresponding data on keyboard as listed in (a) through (e) below:

- (a) **INSTR PRESET** key.
- (b) **START** key, **DATA ENTRY 50 MHz**.
- (c) **STOP** key, **DATA ENTRY 18 GHz**.
- (d) **POWER LEVEL** key, **DATA ENTRY -1 dBm**.
- (e) **SWEEP TIME** key, **DATA ENTRY 100 s**.

TB 9-6625-2124-35

(15) Press **SWEEP TRIGGER SINGLE** key.

(16) Connect power meter to **RF OUTPUT** and **RECORDER OUT** (rear of power meter) to **EXT/MTR ALC INPUT**.

(17) Press **ALC MODE MTR** key and adjust **EXT/MTR ALC CAL** for a power meter indication of -1.0 dBm.

(18) Press **SWEEP TRIGGER SINGLE** key and observe power meter indication. Power meter will indicate -1.0 ± 0.2 dBm during the period the **SWEEP LIGHT** is on.

NOTE

Disregard power meter fluctuations when TI changes bands.

b. Adjustments

NOTE

The exact value of 10 dB attenuator at 50 MHz and 2.2 GHz must be known before performing this adjustment procedure.

(1) Disconnect power meter from **RF OUTPUT**.

(2) Press function keys and enter corresponding data on keyboard as listed in (a) through (o) below:

- (a) **INSTR PRESET** key.
- (b) **CW** key, **DATA ENTRY 50 MHz**.
- (c) **POWER LEVEL** key, **DATA ENTRY -5 dBm**.
- (d) **SAVE** key, **DATA ENTRY 1**.
- (e) **CW** key, **DATA ENTRY 2.2 GHz**.
- (f) **SAVE** key, **DATA ENTRY 2**.
- (g) **POWER LEVEL** key, **DATA. ENTRY 3 dBm**.
- (h) **SAVE** key, **DATA ENTRY 3**.
- (i) **CW** key, **DATA ENTRY 50 MHz**.
- (j) **SAVE** key, **DATA ENTRY 4**.
- (k) **POWER LEVEL** key, **DATA ENTRY 10 dBm**.
- (l) **SAVE** key, **DATA ENTRY 5**.
- (m) **CW** key, **DATA ENTRY 2.2 GHz**.
- (n) **SAVE** key, **DATA ENTRY 6**.
- (o) **RECALL** key, **DATA ENTRY 1**.

(3) Connect power meter to **RF OUTPUT**. Record power meter indication.

(4) Press **RECALL** key and enter data **2** on keyboard. Adjust A4R1 (fig. 11) for power meter indication of equal difference from -5 dBm as the value recorded in (3) above but in the opposite direction (example: if (3) above is -4.9 dBm then A4R1 is adjusted for -5.1 dBm) (R).

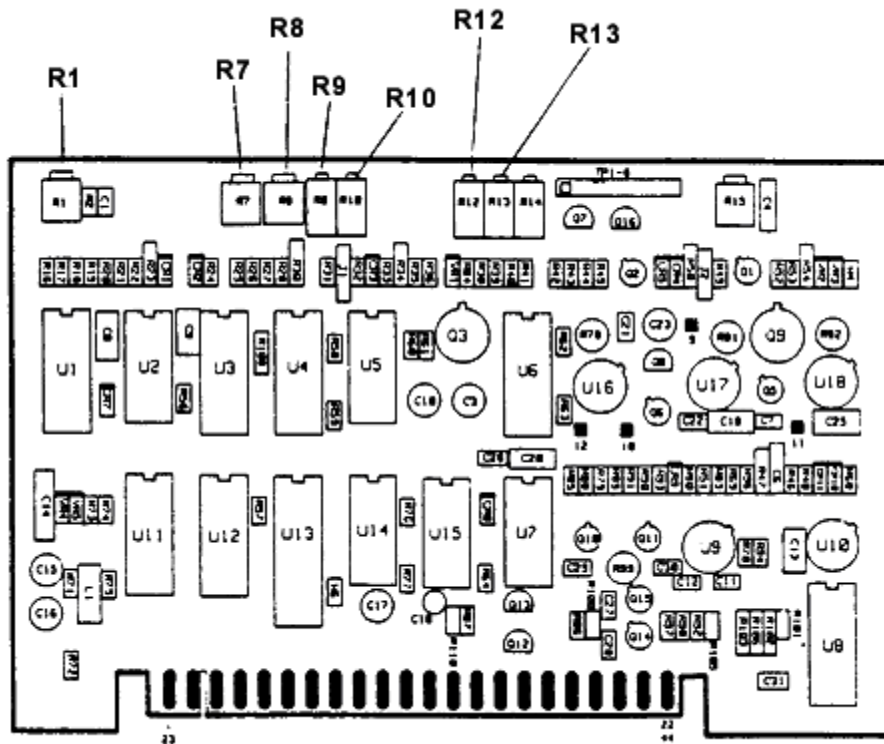

Figure 11. A4 board adjustment locations.

(5) Press **RECALL** key and enter data 1 on keyboard. Adjust A4R13 (fig. 11) for power meter indication of -5.0 dBm (R).

(6) Press **RECALL** key and enter data 4 on keyboard. Record power meter indication.

(7) Press **RECALL** key and enter data 3 on keyboard. Adjust A4R9 (fig. 11) for power meter indication of equal difference from +3 dBm as the value recorded in (6) above but in the opposite direction (R).

(8) Disconnect power meter from **RF OUTPUT**. Connect 10 dB attenuator to **RF OUTPUT** and connect power meter to attenuator.

(9) Press **RECALL** key and enter data 5 on keyboard. Add power meter indication to exact value of attenuator (at 50 MHz) and record.

(10) Press **RECALL** key and enter data 6 on keyboard. Adjust A4R7 (fig. 11) for power meter indication plus attenuator value (at 2.2 GHz) of equal difference from +10 dBm as the value recorded in (9) above but in the opposite direction (R).

(11) Press **RECALL** key and enter data 2 on keyboard. Record power meter indication.

(12) Adjust **FREQUENCY VERNIER** control to tune TI output frequency to the start of band 2 (approximately 2.5 GHz).

NOTE

When performing (12) above, a sharp drop in power meter indication will be observed at the end of band 1 (band breakpoint). Continue to manually tune TI output frequency until power meter indication returns.

- (13) Adjust A4R12 (fig. 11) for power meter indication equal to value recorded in (11) above (R).
- (14) Press **RECALL** key and enter data of **3** on keyboard. Record power meter indication.
- (15) Repeat (12) above.
- (16) Adjust A4R10 (fig. 11) for power meter indication equal to value recorded in (14) above (R).
- (17) Press **RECALL** key and enter data **6** on keyboard. Record power meter indication.
- (18) Repeat (12) above.
- (19) Adjust A4R8 (fig. 11) for power meter indication equal to value recorded in (17) above (R).
- (20) Repeat (1) through (19) above until no further adjustment is required.
- (21) Connect **SWEEP OUTPUT** to oscilloscope **CH2** input.
- (22) Connect semiconductor device to **RF OUTPUT** and connect oscilloscope **CH1** input to semiconductor device.
- (23) Press function keys and enter corresponding data on keyboard as listed in (a) through (e) below:
 - (a) **INSTR PRESET** key.
 - (b) **START** key, **DATA ENTRY 10 MHz**.
 - (c) **STOP** key, **DATA ENTRY 18 GHz**.
 - (d) **POWER LEVEL** key, **DATA ENTRY 10 dBm**.
 - (e) **RF BLANK (ON)**.
- (24) Set oscilloscope for an X verses Y operation and adjust controls as necessary to display the TI output.
- (25) Set A5R34, A5R36, A5R38, and A5R40 (fig. 12) fully cw.
- (26) Adjust A5R48 (fig. 12) for best overall trace flatness as displayed on oscilloscope (R).
- (27) Adjust BP (breakpoint) and SL (slope) adjustments listed in table 8 for best overall trace flatness as displayed on oscilloscope.

Table 8. BP and SL Adjustments

BP adjustment (fig. 12)	SL adjustments (fig. 12) (R)
BP1 A5R34	SL1 A5R41
BP2 A5R36	SL2 A5R42
BP3 A5R38	SL3 A5R43
BP4 A5R40	SL4 A5R44

NOTE

The BP adjustment determines at what frequency the corresponding SL adjustment takes effect.

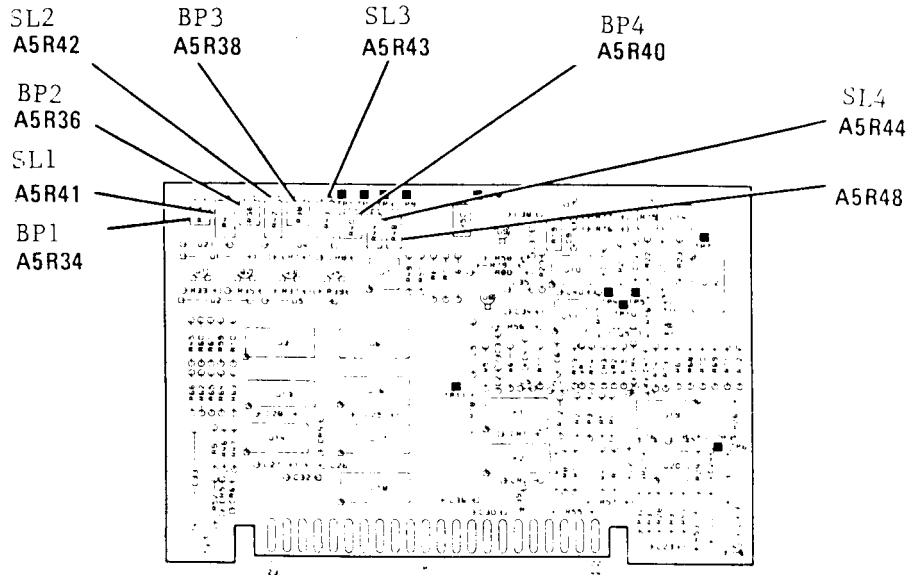

Figure 12. A5 board adjustment locations.

23. Step Attenuator Accuracy (Option 002 only)

a. Performance Check

- (1) Connect measuring receiver to **RF OUTPUT**.
- (2) Press function keys and enter corresponding data on keyboard as listed in (a) and (b) below:
 - (a) **CW** key, **DATA ENTRY 12 GHz**.
 - (b) **POWER LEVEL** key, **DATA ENTRY 0 dBm**.
- (3) Press **RF ON/OFF** key to **ON** and establish a reference on measuring receiver at 12 GHz.
- (4) Make **POWER LEVEL** data entries as listed in table 9. Using standard tuned level measurement techniques, measured power will indicate within limits specified.

Table 9. Step Attenuator Setting

Test instrument power level data entries	Receiver system indications (dB)			
	12 GHz		18 GHz	
	Min	Max	Min	Max
-10	-9.4	-10.6	-9.3	-10.7
-20	-19.3	-20.7	-19.1	-20.9
-30	-29.1	-30.9	-28.8	-31.2
-40	-38.2	-41.8	-38.0	-42.0

Table 9. Step Attenuator Setting Continued

Test instrument power level data entries	Receiver system indications (dB)			
	12 GHz		18 GHz	
	Min	Max	Min	Max
-50	-48.0	-52.0	-47.7	-52.3
-60	-57.8	-62.2	-57.5	-62.5
-70	-67.7	-72.3	-67.2	-72.8

(5) Press function keys and enter corresponding data on keyboard as listed in (a) and (b) below:

- (a) **CW** key, **DATA ENTRY 18 GHz**.
- (b) **POWER LEVEL** key, **DATA ENTRY 0 dBm**.

(6) Repeat (3) and (4) above at 18 GHz.

b. Adjustments. No adjustments can be made.

24. AM ON/OFF Ratio and Square Wave Symmetry

a. Performance Check

- (1) Connect spectrum analyzer to **RF OUTPUT**, using 10 dB attenuator.
- (2) Press function keys and enter corresponding data on keyboard as listed in (a) through (d) below:
 - (a) **INSTR PRESET** key.
 - (b) **CW** key, **DATA ENTRY 1 GHz**.
 - (c) **POWER LEVEL** key, **DATA ENTRY 10 dBm**.
 - (d) \square **MOD (ON)** key.
- (3) Adjust spectrum analyzer controls as necessary to display the TI output signal.
- (4) Measure AM ON/OFF ratio and square wave symmetry; AM ON/OFF ratio will be greater than 30 dB and square wave symmetry will be 40/60 percent.
- (5) Press **CW** key and enter data **4 GHz** on keyboard. Repeat (3) and (4) above.

b. Adjustments. No adjustments can be made.

25. Final Procedure

- a.** Deenergize and disconnect all equipment.
- b.** Annotate and affix DA label/form in accordance with TB 750-25.

By Order of the Secretary of the Army:

Official:



JOEL B. HUDSON
*Administrative Assistant to the
Secretary of the Army*

0413102

PETER J. SCHOOMAKER

*General, United States Army
Chief of Staff*

Distribution:

To be distributed in accordance with the initial distribution number (IDN) 342238, requirements for calibration procedure TB 9-6625-2124-35.

Instructions for Submitting an Electronic 2028

The following format must be used if submitting an electronic 2028. The subject line must be exactly the same and all fields must be included; however, only the following fields are mandatory: 1, 3, 4, 5, 6, 7, 8, 9, 10, 13, 15, 16, 17, and 27.

From: "Whomever" whomever@redstone.army.mil
To: <2028@redstone.army.mil

Subject: DA Form 2028

1. **From:** Joe Smith
2. **Unit:** home
3. **Address:** 4300 Park
4. **City:** Hometown
5. **St:** MO
6. **Zip:** 77777
7. **Date Sent:** 19-OCT -93
8. **Pub no:** 55-2840-229-23
9. **Pub Title:** TM
10. **Publication Date:** 04-JUL-85
11. **Change Number:** 7
12. **Submitter Rank:** MSG
13. **Submitter FName:** Joe
14. **Submitter MName:** T
15. **Submitter LName:** Smith
16. **Submitter Phone:** 123-123-1234
17. **Problem:** 1
18. **Page:** 2
19. **Paragraph:** 3
20. **Line:** 4
21. **NSN:** 5
22. **Reference:** 6
23. **Figure:** 7
24. **Table:** 8
25. **Item:** 9
26. **Total:** 123
27. **Text**

This is the text for the problem below line 27.

